

REVISIONS				
REV.	DESCRIPTION	DATE	ECN	INITIALS
A	INITIAL RELEASE	10/7/2020	3692	TDJ
B	UPDATE BODY DIAMETER	09/07/22	4105	MRA

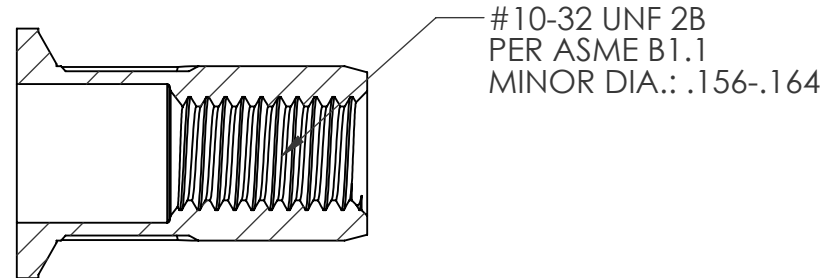
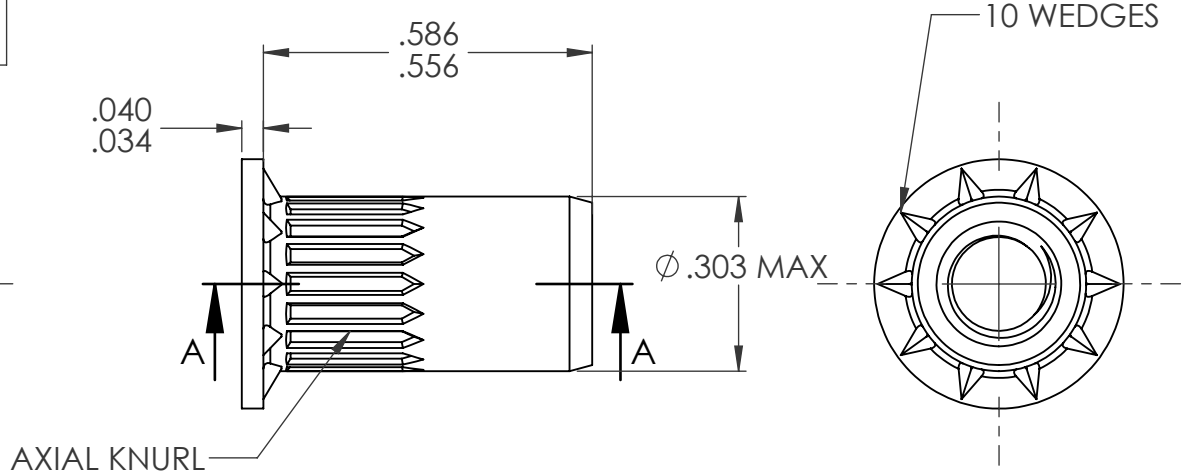
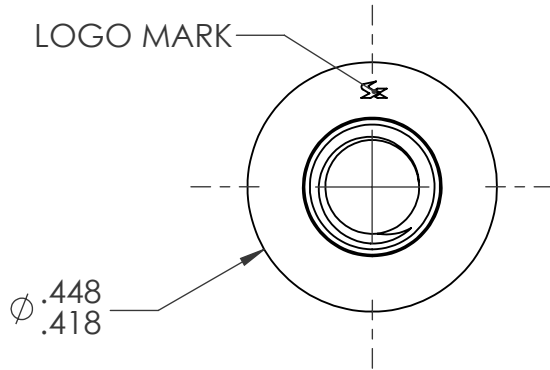

SECTION A-A

NOTE:

- GRIP RANGE: .059-.118
- HOLE SIZE: .300+.006/-0.000 AFTER ALL APPLIED FINISHES.
- INSTALLED LENGTH: .413 MAX.
- LUBRICATION: NONE
- INSTALLATION TOOL: SPIN PULL

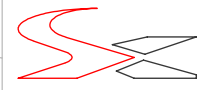
CUSTOMER APPROVAL:				UNLESS OTHERWISE SPECIFIED:				NAME		DATE					
DATE:				DIMENSIONS ARE IN INCHES TOLERANCES: ANGULAR: MACH ±1 BEND ±1 TWO PLACE DECIMAL ±.01 THREE PLACE DECIMAL ±.005		DRAWN		TDJ		10/7/2020				<b>TITLE:</b> #10-32 OPEN END LARGE FLANGE OPTISERT	
				INTERPRET GEOMETRIC TOLERANCING PER: ASME Y14.5M-1994		CHECKED		CL		10/7/2020					
				MATERIAL C1008/C1010		ENG APPR.		JVK		10/7/2020		<b>REV</b> <b>B</b>			
		NEXT ASSY		USED ON		FINISH ZINC PLATE CLEAR TRIVALENT CHROMATE PER SFS-01-001; SC1		MFG APPR.						<b>SCALE: 3:1</b> <b>WEIGHT:</b>	
				APPLICATION		DO NOT SCALE DRAWING		Q.A.				<b>SHEET 1 OF 1</b>			
								COMMENTS: E-mail: info@sherex.com www.sherex.com Phone: 866-474-3739 Fax: 716-875-0358							

**PROPRIETARY AND CONFIDENTIAL**  
THIS DRAWING, AND THE INFORMATION CONTAINED HEREIN, ARE THE PROPERTY OF SHEREX AND ARE NOT TO BE USED IN ANY MANNER DETRIMENTAL TO THE INTEREST OF THE COMPANY.  
SHEREX SOLUTIONS RESERVES THE RIGHT TO REVISE PART/DRAWING WITHOUT NOTICE.  
UNLESS OTHERWISE SPECIFIED, ALL SPECIFICATIONS REFERENCED ON THIS DRAWING WILL PERTAIN TO THE MOST RECENT AND ACTIVE REVISION.